

TM3200, TM3210

GEAR CASE

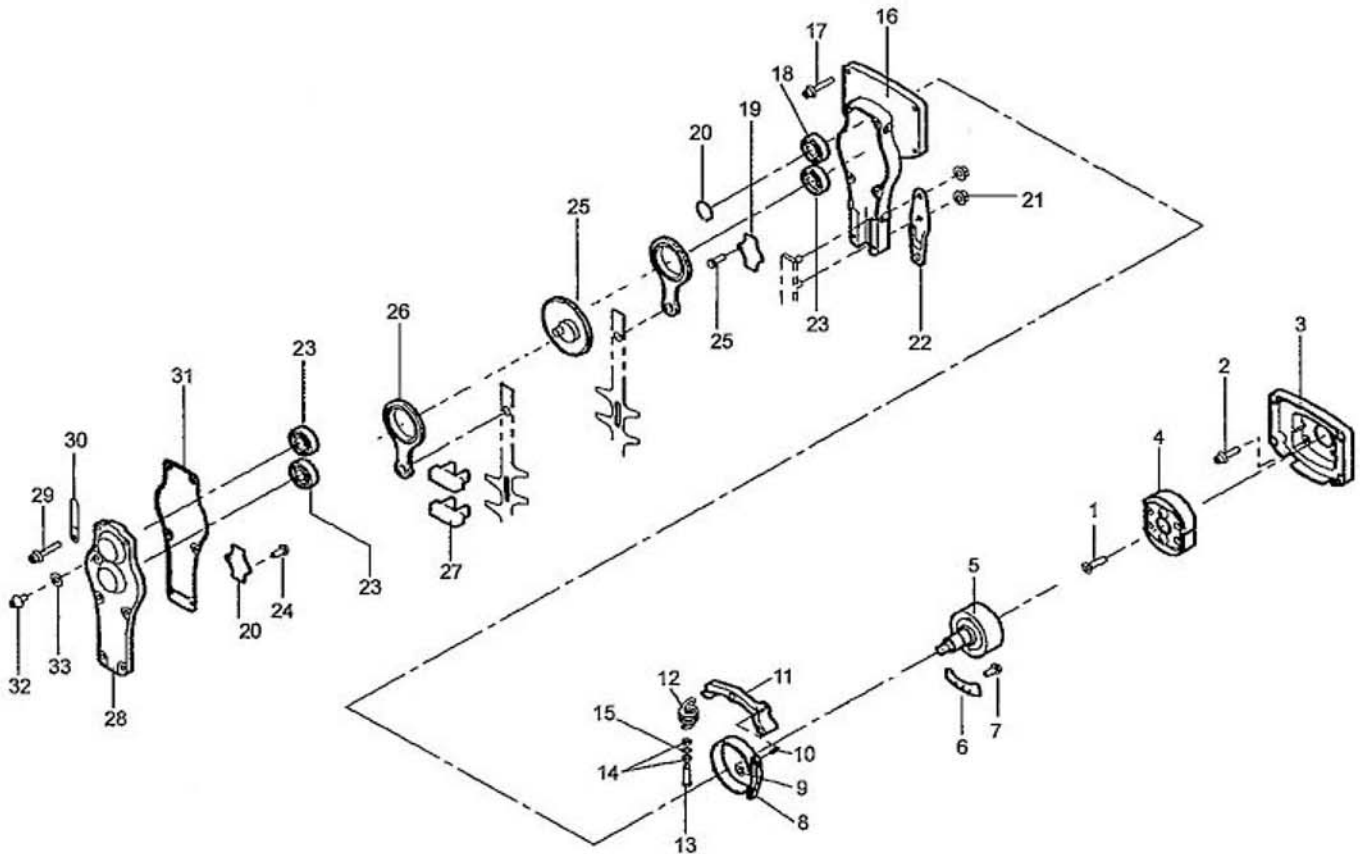

PARTS LIST

REF. No.	PARTS No.	PARTS NAME	Q'TY		REMARKS
				INCLUDING	
1	375L 0620	(+)-FLAT SCREW	1		M6 × 20
2	423U 0515	SOCKET SCREW FLANGE	4		M5 × 15
3	51070 129	ENGINE BASE	1		
4	71019 118	CLUTCH SHOE ASS'Y	1		
5	11014 216	CLUTCH DRUM C.P.	1		
6	11050 169	FIXING PLATE	1		
7	423U 0408	SOCKET SCREW FLANGE	1		M4 × 8
8	68053 103	BRAKE BAND	1		
9	612L 0400	PLAIN WASHER	1		
10	711V 0416	SPRING PIN	1		M4 × 16
11	11104 158	ARM	1		
12	68013 324	SPRING	1		
13	31032 106	ADJUST SCREW	1		
14	31058 160	HEXAGON NUT	2		M6
15	611L 0600	PLAIN WASHER	1		M6
16	51068 106	CAM CASE	1		
17	423U 0518	SOCKET SCREW FLANGE	4		M5 × 18
18	954B 6003	BEARING	1		6003 ZZ C3
19	11050 168	FIXING PLATE	2		
20	812V 1700	C-SNAPRING FOR SHAFT	1		Φ17
21	571L 0600	HEXAGON NUT FLANGE	2		M6
22	11102 208	HOLDER	1		
23	954B 0629	BEARING	3		629 ZZ C3
24	31062 152	LOCK COAT (+) SCREW	4		M4 × 8
25	78004 256	GEAR	1		

TM3200, TM3210

CUTTER , HANDLE

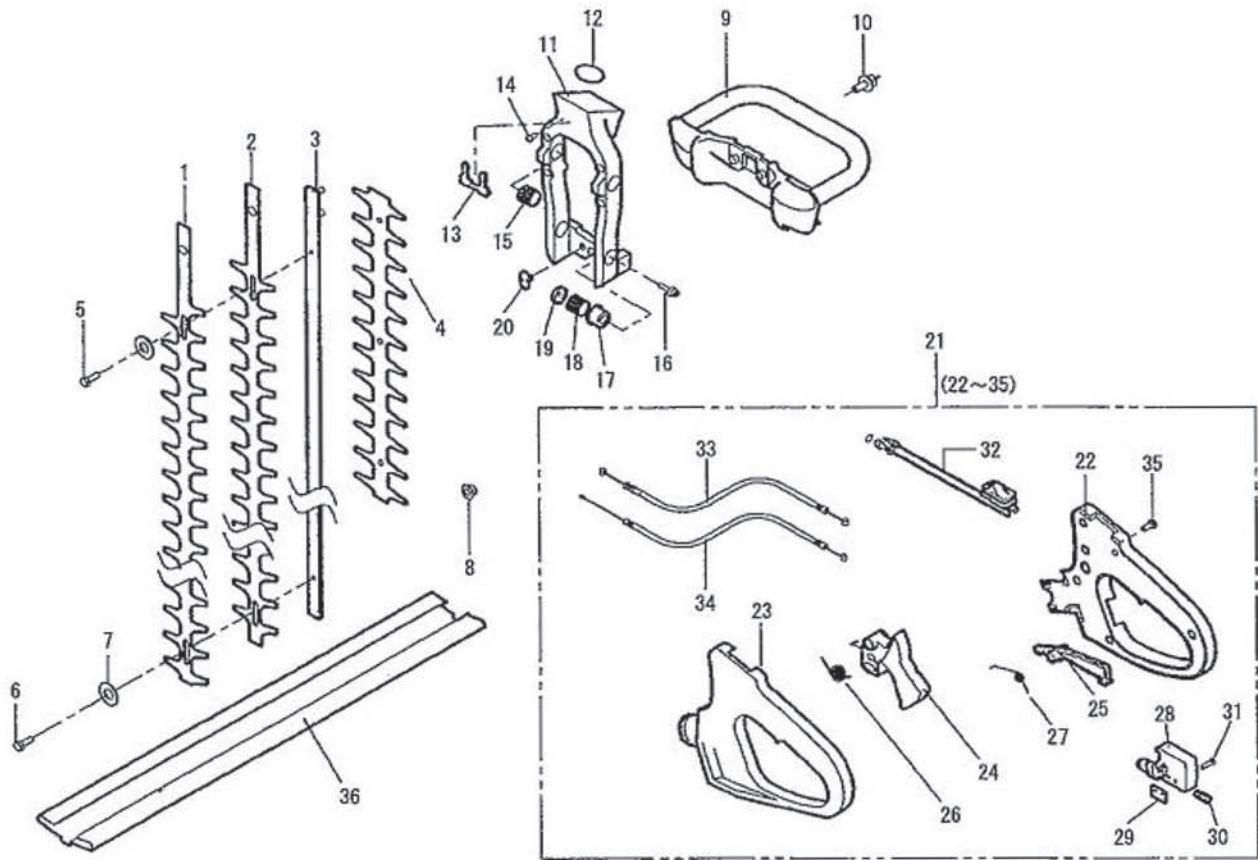

PARTS LIST

REF. No.	PARTS No.	PARTS NAME	Q'TY		REMARKS
				INCLUDING	
1	91053 123	CUTTER(A)	1		
2	91054 116	CUTTER(B)	1		
3	11051 128	CUTTER GUIDE	1		
4	51090 122	PROTECTOR	1		
5	31029 105	STEP BOLT (S)	1		
6	31029 110	STEP BOLT (S)	4		
7	68002 101	CUTTER WASHER	5		
8	584L 0600	U-HEXAGON NUT FLANGE	5		M6
9	51027 238	HANDLE	1		
10	31057 235	BOLT	2		M5 x 20
11	51022 171	BRACKET	1		
12	214B 5000	O-RING	1		S50
13	11086 179	STOPPER	1		
14	477L 0408	(+) TRUSS TAPPING SCREW	2		
15	68013 326	SPRING	2		
16	423U 0515	SOCKET SCREW FLANGE	4		
17	11102 210	HOLDER	4		
18	68013 327	SPRING	2		
19	11102 209	HOLDER	4		
20	31038 102	FIXING NUT	2		
21	71014 368	HANDLE ASSY	1		
22	51106 127	HANDLE R	1		
23	51106 128	HANDLE R	1		
24	91010 190	THROTTLE LEVER	1		
25	36081 113	LOCK LEVER	1		

